

THS/PLV

INTEGRATED SYSTEM WITH EJECTION VALVES FOR LIQUID AND VISCOUS PRODUCTS



- 1) DETECTION HEAD
- 2) AIR COMPRESSED VALVES BOX
- 3) EJECTOR
- 4) P.I.E
- 5) AIR COMPRESSED TANK
- 6) CLAMP



Very High Detection Sensitivity to all magnetic and non-magnetic metals, including stainless steel
Full compliance with HACCP criteria
Standard pipe sizes available to suit all applications
Fast acting reject device for a limited quantity of rejected product
Completely housed in AISI 316L Stainless Steel
Ease to clean and inspect
Minimum Installation Space required
Very High Reliability
Maximum Operator Safety

The THS/PLV is a compact integrated system designed for metal contaminant detection and elimination in products transported by pipeline especially meat, soup, preserves... The D.S.P. Digital Signal Processing of the Metal Detector Antenna signals allows a very high degree of sensitivity to be obtained for all metals.

The carefully-selected materials used in construction do not interact with food products, and thus do not modify or alter their composition. The design of these systems incorporates a fast response time to drive the reject valve and to detect and reject the contaminant without slowing down the product flow.

The construction guarantees quick, easy cleaning of the components that are in contact with the product. The technological choices made by CEIA allow the parts in contact with the product to be disassembled and maintained in a short time. THS/PLV system can be linked to local computer

networks via a RS-485 interface.

The THS/PLV System operates in Fail-Safe Mode, thus avoiding the risk of contaminants passing through even when the system is deactivated or when the electrical power supply is interrupted.

THS/PLV PIPELINE METAL DETECTION SYSTEM

GENERAL FEATURES

- Stainless Steel AISI 31 6L and FDA approved plastic composition for all parts in contact with the product
- Fast disassembly and cleaning
- Fail-Safe working
- Very High Throughput
- Precise ejection of the contaminated product

METAL DETECTION FEATURES

- Very High Sensitivity to Ferrous, Non-Ferrous and Stainless Steel Metals
- Very High Immunity to external electrical and mechanical interferences
- Automatic Balancing
- Built-In Self Diagnosis System

PRODUCTION DATA MANAGEMENT

- Complete Production Logging (using dump of the internal memory or THS Report):
 - Ejections
 - Test Results
- Network Interface: RS-485

SIGNALING

- Acoustic
- Optical

PROGRAMMING

- Local: Keyboard and 80 character LCD Display
- Remote via RS-232 , RS-485

I/O AND ENVIRONMENTAL DATA

- Power Supply: 115/230 Vac -22%; +10 %, 48-62 Hz, 60 VA
- Air compressed 0,6 ÷ 1 MPa
- Operating Temperature: -10 ÷ +55 °C
- Relative Humidity: 0-95% (without Condensation)
- Relay outputs
 - Metal Detector Alarm
 - Ejection
 - Test request
 - Fault
- Direct RS-232 connection to Printer or Personal Computer

CERTIFICATION AND CONFORMITY

- Conforms to current Requirements for Pipeline Metal Detection Systems.
- Complies with EC Regulations and International Standards relating to Electrical Safety and Electromagnetic Compatibility.

MODEL	CLAMP DIAMETER (MM)
THS/PLV-38	38
THS/PLV-50	50
THS/PLV-63	63
THS/PLV-75	75
THS/PLV-100	100

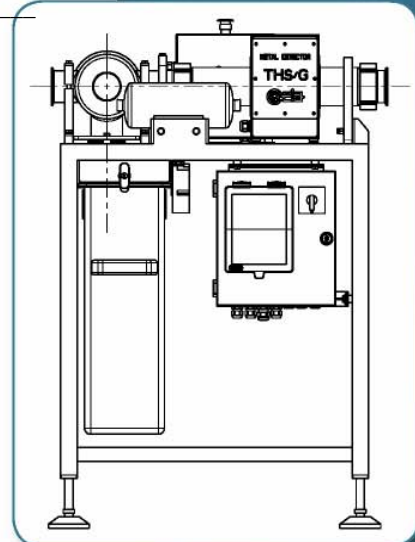

THS/PLV-XX FRONT VIEW

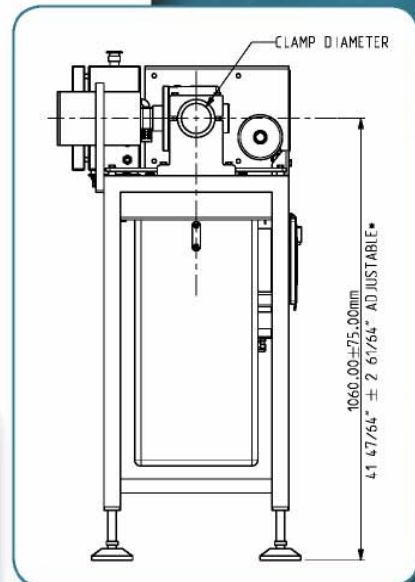

THS/PLV-XX SIDE VIEW
* DIFFERENT HEIGHTS AVAILABLE UPON REQUEST

PT JOTAM

Ph: 021 4523089

Fax: 021 4515743

Email: jotam@cbn.net.id

